

ND Electric valve

ND Electric valve

Primary applications: for dripline, micro-sprinkler and sprinkler systems in residential and public gardens, parks, hotels and tourist resorts

Main features

- 3/4" - 2" Electric valve
- High performance solenoid with low power consumption
- Very high flow rate with very low head loss
- Operation over a wide range of pressures
- Smooth valve opening and closing prevents pressure surge
- Flow control handle for water flow adjustment
- Manual solenoid override

Technical data

Pressure rating: ISO PN 6; ANSI class 125

Working pressure: 0.7 - 6 bar

Electrical data: 24VAC; holding 0.20A, inrush 0.40A



3/4" & 1"

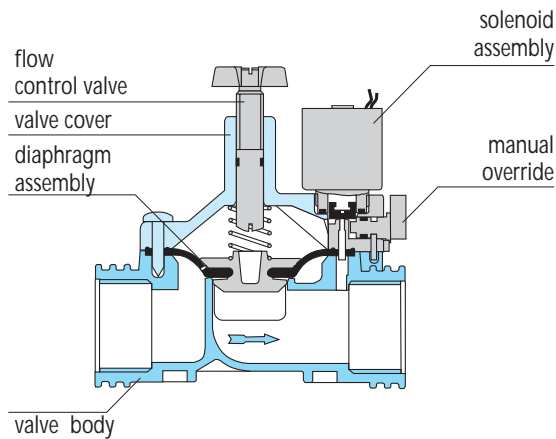

1.5" & 2"

